

DIN 319

Ball knobs

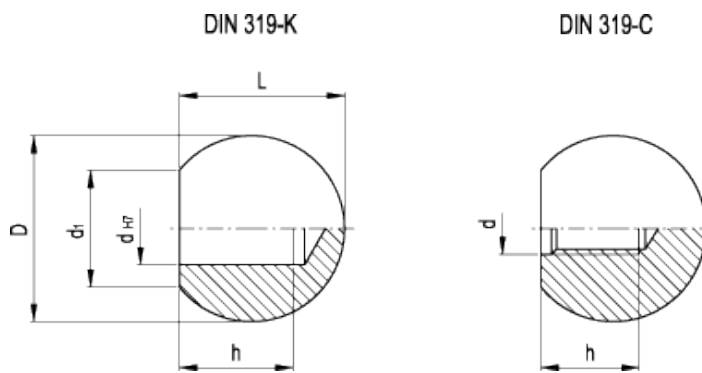

technical informations

Material

- Version ST: polished steel.
- Version AL: polished aluminium.

Assembly

- Version K: H7 plain hole.
- Version C: tapped blind hole.

Standard Elements	Main dimensions			Mounting hole			Weight
Description	D	L	d ₁	d	d _{H7}	h _{min}	g
DIN 319-ST-16-B6-K	16	15	8	-	6	9	14
DIN 319-ST-16-M4-C	16	15	8	M4	-	7.2	15
DIN 319-AL-16-B6-K	16	15	8	-	6	9	5
DIN 319-AL-16-M4-C	16	15	8	M4	-	7.2	6
DIN 319-ST-20-B8-K	20	18	12	-	8	11	25
DIN 319-ST-20-M5-C	20	18	12	M5	-	9.1	26
DIN 319-AL-20-B8-K	20	18	12	-	8	11	10

DIN 319-AL-20-M5-C	20	18	12	M5	-	9.1	11
DIN 319-ST-25-B10-K	25	22.5	15	-	10	14	50
DIN 319-ST-25-M6-C	25	22.5	15	M6	-	11	59
DIN 319-AL-25-B10-K	25	22.5	15	-	10	14	18
DIN 319-AL-25-M6-C	25	22.5	15	M6	-	11	21
DIN 319-ST-32-B12-K	32	29	18	-	12	17	106
DIN 319-ST-32-M8-C	32	29	18	M8	-	14.5	116
DIN 319-AL-32-B12-K	32	29	18	-	12	17	39
DIN 319-AL-32-M8-C	32	29	18	M8	-	14.5	43
DIN 319-ST-40-B16-K	40	37	22	-	16	22	206
DIN 319-ST-40-M10-C	40	37	22	M10	-	18	235
DIN 319-AL-40-B16-K	40	37	22	-	16	22	75
DIN 319-AL-40-M10-C	40	37	22	M10	-	18	85
DIN 319-ST-50-B20-K	50	46	27	-	20	28	384
DIN 319-ST-50-M12-C	50	46	27	M12	-	21	475
DIN 319-AL-50-B20-K	50	46	27	-	20	28	146
DIN 319-AL-50-M12-C	50	46	27	M12	-	21	169



STANDARD MACHINE ELEMENTS WORLDWIDE